



SPECTRUM™ ARCH INSTALLATION MANUAL

(ALL COLORS)

Equipment Features

- Aluminum Structure Plastic Wrap
- Appealing Round Arch Manifold
- Quick Disconnect Nozzles
- Available with "V" jet and Foaming Nozzle
- Optional "LED." Light Kit Available

Equipment Specifications

	SPECTRUM ARCH K-FOAMER	SPECTRUM ARCH V-NOZZLES
TUNNEL LENGTH	8"	8"
TUNNEL WIDTH	144"	144"
UNIT HEIGHT	97"	97"
VEHICLE CLEARANCE	90"	90"
ELECTRICAL	N/A	N/A
PNEUMATICS	2 SCFM	N/A
	(2) 3/8"OD AIR LINE PUSH-IN FITTING	
WATER	5 GPM (max)	5-15 GPM (max)
	(2) 3/8"OD AIR LINE PUSH-IN FITTING	3/4" HOSE BARBED FITTING

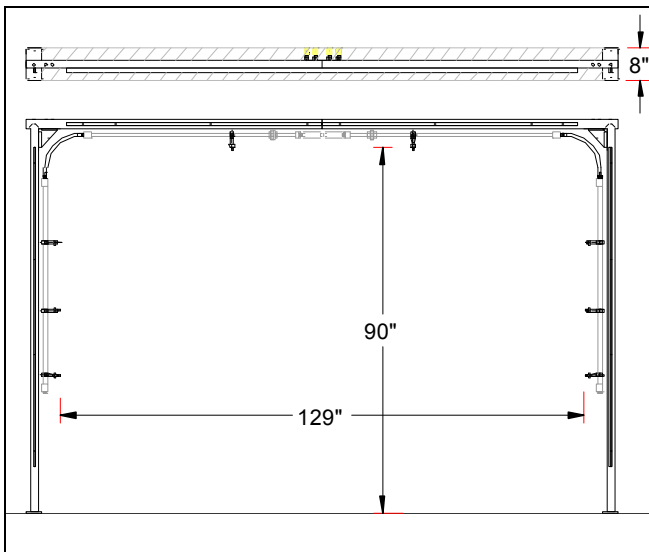

Pic #1: K-Nozzle Arch

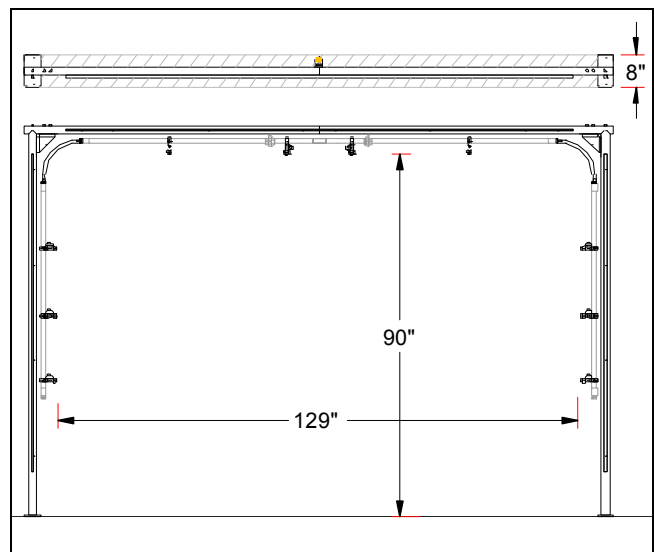

Pic #2: V-Nozzle Arch

TABLE OF CONTENT

Equipment Specifications.....	Page: 1
Equipment Features.....	Page: 1
Suggested Tools and Installation Materials.....	Page: 2
Installation Instructions.....	Page: 2
Optional Light Kit.....	Page: 6

Suggested Installation Tools and Materials

- | | |
|--|---|
| <input checked="" type="checkbox"/>  Hammer Drill with 1/2" Drill Bit | <input type="checkbox"/> (8) Wedge Anchor Bolts 1/2" x 3-3/4" |
| <input type="checkbox"/> Sledge Hammer | <input type="checkbox"/> Robertson Red #2 Square Screwdriver |
| <input type="checkbox"/> Set of Standard Combo Wrenches | <input type="checkbox"/> Torpedo Level |
| <input type="checkbox"/> Measuring Tape | <input type="checkbox"/> 6' Step Ladder |

Notes and safety Symbols

Where necessary, important points will be highlighted in this manual, using the following symbols:

 **NOTES: PROVIDES FURTHER INFORMATION!**

 **STOP! PRECAUTION TO TAKE TO AVOID EQUIPMENT MALFUNCTION OR ERROR!**

 **WARNING! DANGEROUS SITUATION WHICH MAY CAUSE EQUIPMENT DAMAGES, PERSONAL INJURIES OR FATALITIES!**

Always follow all "Notes", "Warning" and instructions. Not doing so may have serious consequences on the overall performance of the equipment and/or the safety of the people working on the equipment!

Installation Procedures

-  **Upon** receiving your MCWW equipment, open all boxes and crates and verify that you have all the required components as well as there are no damages to the equipment. Verify also that you have all your installation material.
- Remove** packaging material covering your **MCWW ARCH** and bring it to the wash in the area where it will be installed and verify that the area is sufficiently large for the **MCWW SPECTRUM ARCH WORKING ENVELOPE** and **DIMENSIONS** (see Picture #1 and #2).

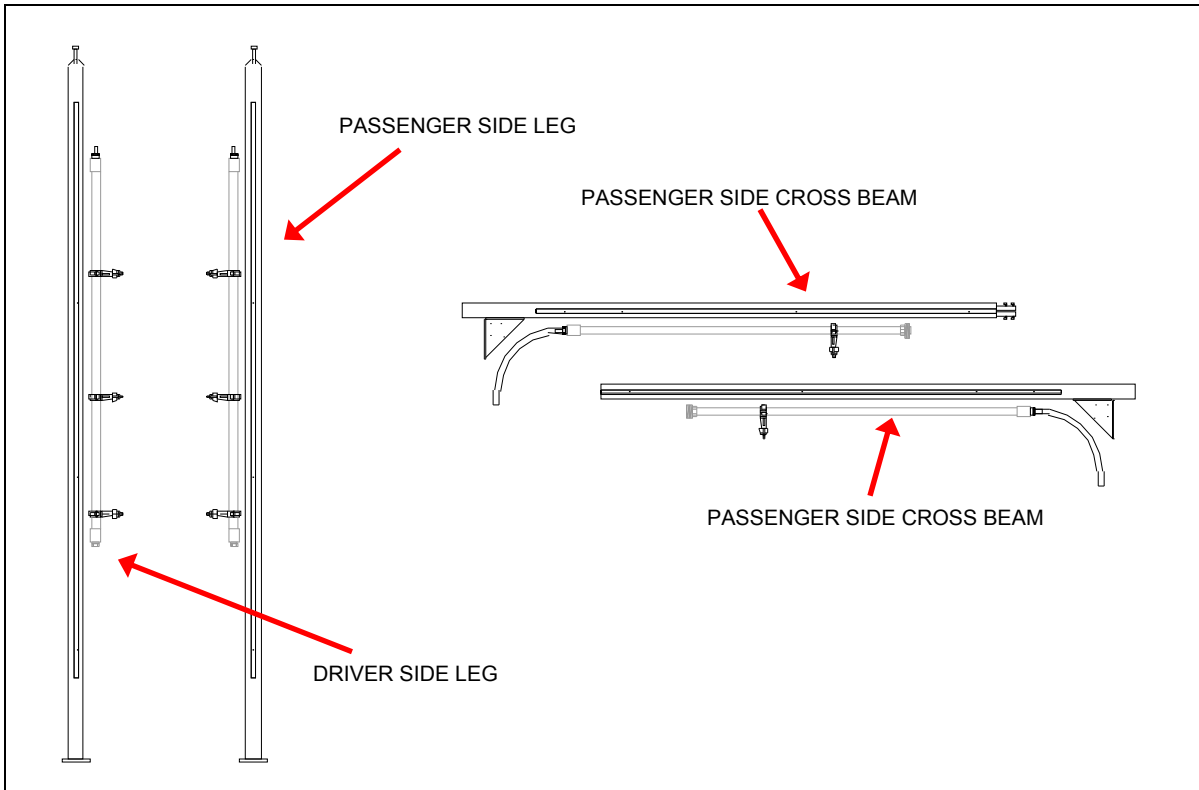

Pic #3: Legs and Cross Beams



Pic #4: Cross Beam Mating Brackets



Pic #5: Cross Beam Secured



STOP!

THE ENTRANCE SIDE OF THE CROSS BEAMS AS WELL AS THE LEGS HAS ALUMINUM CHANNELS FOR LED LIGHT STRING

- Assemble** the arch on the floor by connecting the **CROSS BEAMS TOGETHER** (see Picture #4 and #5).
- Locate** the **PASSENGER SIDE** leg assembly and secure to the main cross beam like shown on Picture #6. The main cross beam as well as the legs comes complete with all the mounts conveniently secured at the factory. Insure that both are oriented in the same direction (see **NOTES** below).
- Connect** the water hose to the hose fitting on the leg manifold (see Picture #8)



Pic #6: Assembling Passenger Leg



Pic #7: Secure Corner Bracket

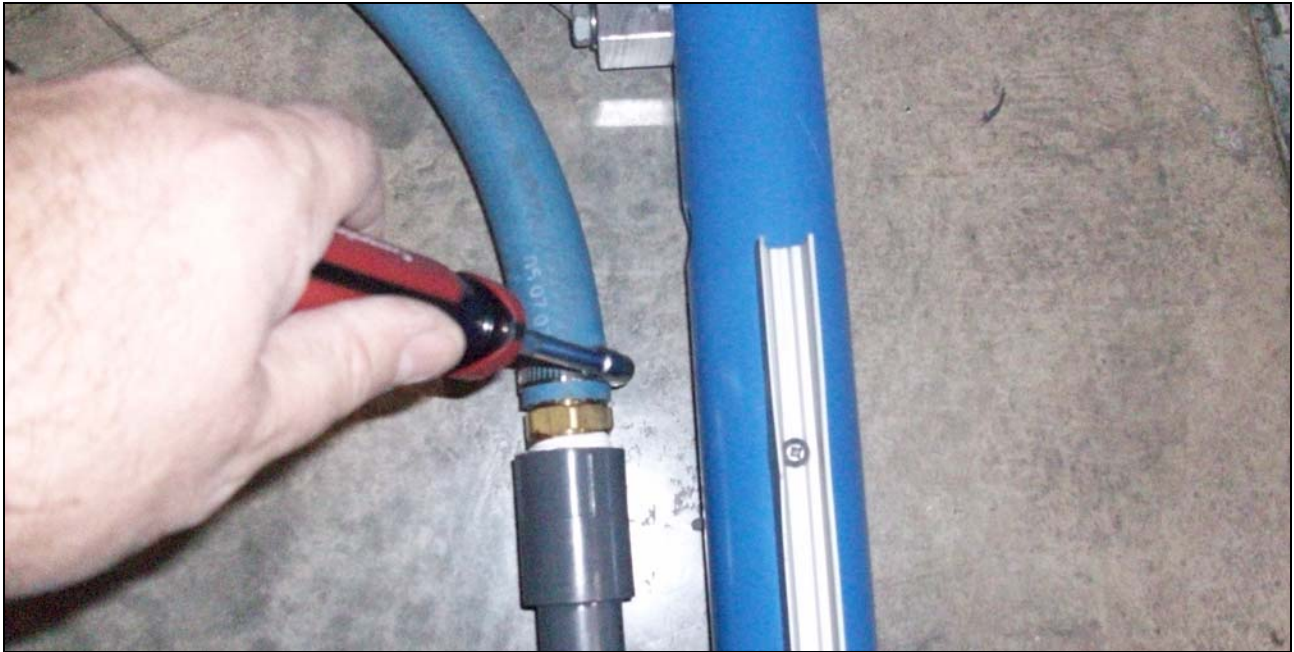

Pic #9: Connect Hose

- Repeat** the same process for the **DRIVER SIDE LEG**.
- Secure** the **TEE MANIFOLD** between the two manifolds if the arch is a **V-NOZZLE ARCH**. Secure a foamer generator on each arch manifold if the arch is a **K-NOZZLE ARCH** (see pictures #10 and 11 below).

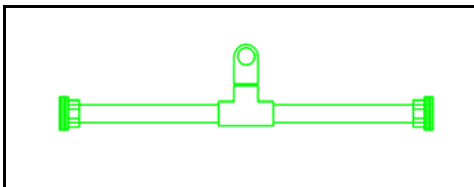

Pic #10: V Nozzle Arch Tee Manifold

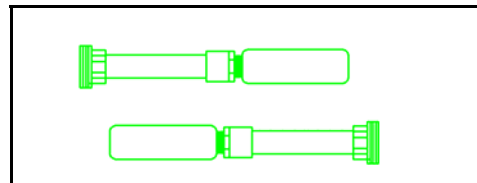

Pic #11: K-Foamer Generators

- **Raise** the arch and secure to the floor with four (4) 1/2" anchor bolts (2 for each side) like shown on picture #12.

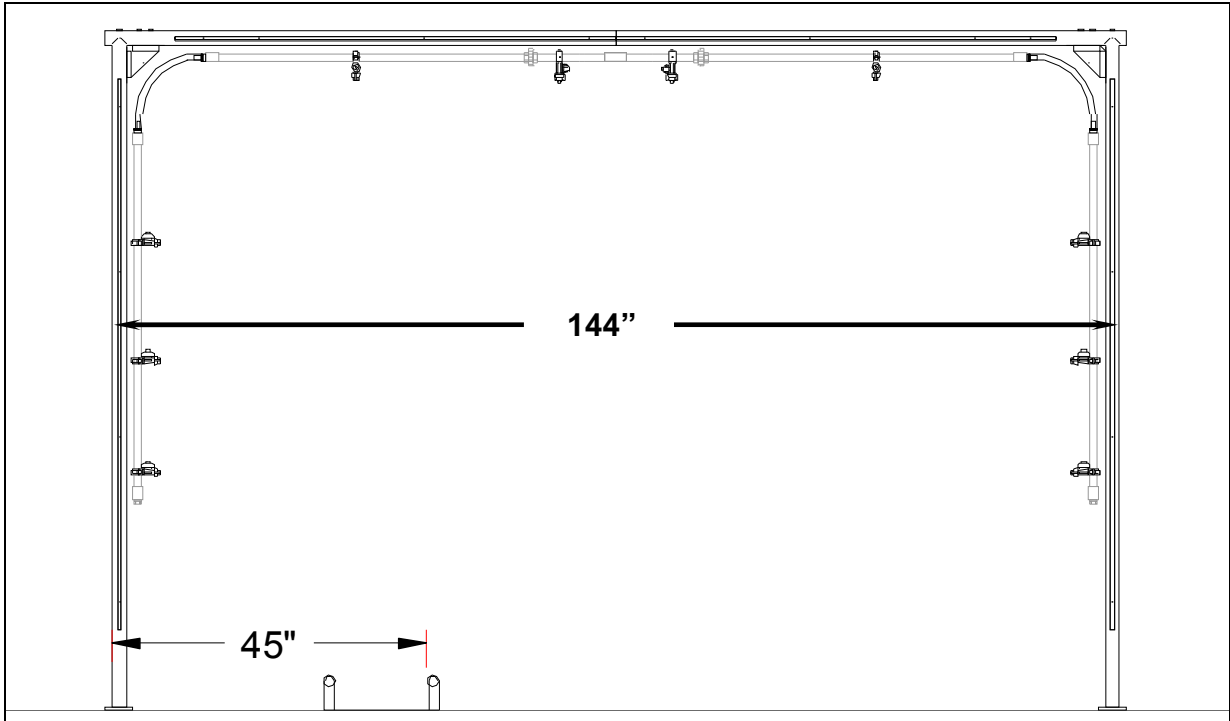

Pic #12: Arch Installation

- **If you have a V-NOZZLE ARCH**, connect the arch to a dilution station of greater capacity than the arch total volume like show below.

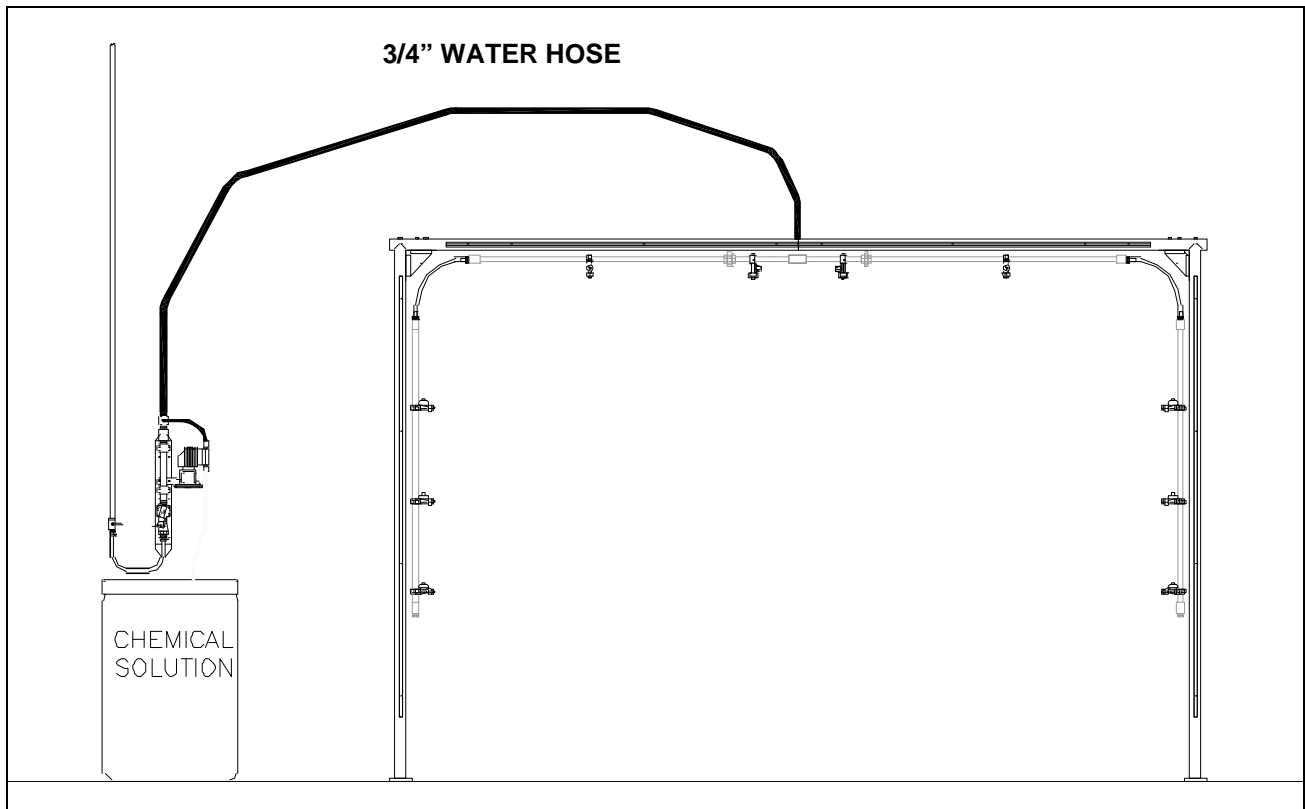

Pic #13: Water Connections

If you have a **K-NOZZLE** arch, connect the arch to a foaming dilution station like show below.

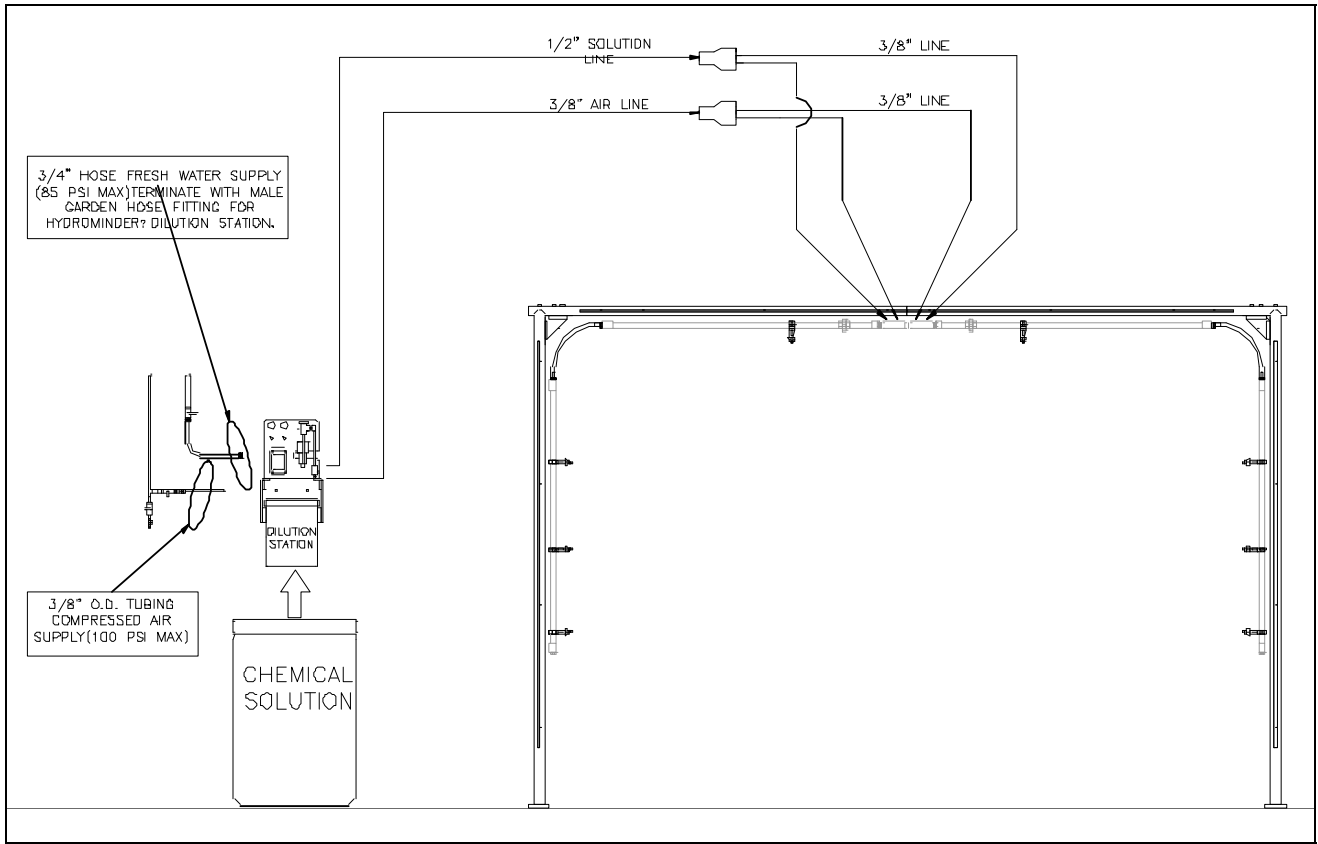

Pic #14: Air and Chemical Connections

LED Border Light And Round Sign Installation Procedure:

Electrical Specifications:	Light Kit.....24VDC
	Power Supply.....120VAC Supply
	Flasher Unit.....24 or 120VAC or 24VDC Coil

Verify that you have all the required components as well as there are no damages to the equipment. Verify also that you have all your installation material.



Pic #13: LED String



Pic #14: LED Round Sign

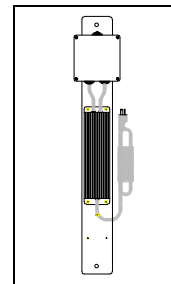

Pic #15 Flasher Unit

Locate the mark indicating the middle of the light string and insert the light string in the **ALUMINUM CHANNEL** mounted on the cross beam (see Picture below) starting from the center of the cross beam aluminum channels.

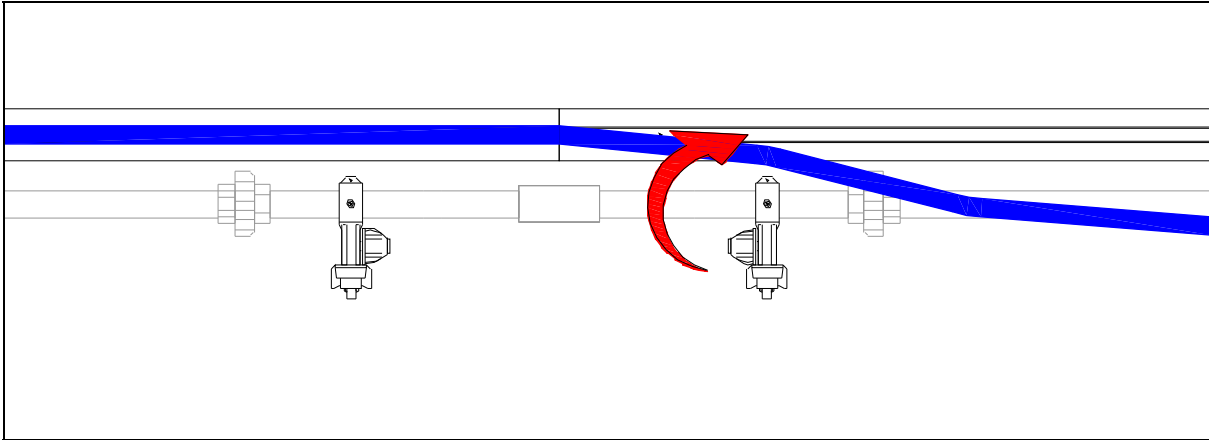

Pic #17 LED String and Mounts

- Pull** the LED String cable through the utility hole (see Picture #18) and pull it out from the large utility opening located on the side of the leg.

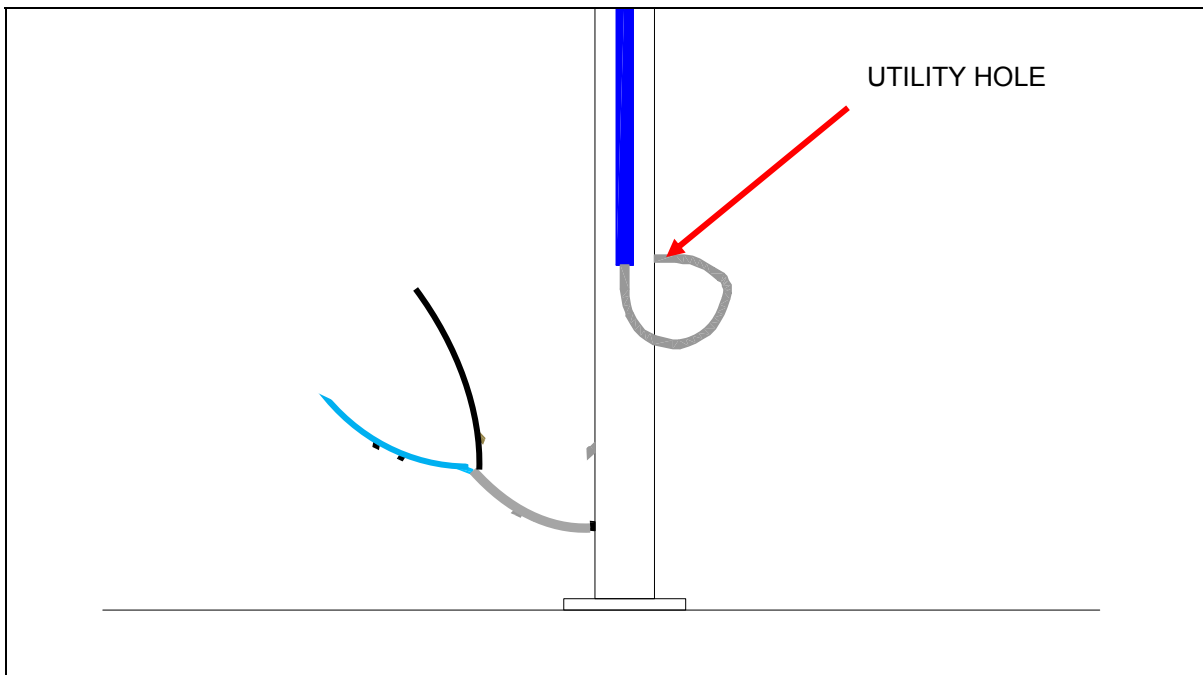

Pic #18 Pull LED String Cable

Installation Procedures For LED Round Sign:

- Remove** the **DRIVER SIDE WATER MANIFOLD** from the leg by opening the clamp, remove the **SADDLE** (see picture #19) from behind the clamp and secure the sign mount as well as the manifold clamp using the pre-existing drilled holes (see Picture #20).

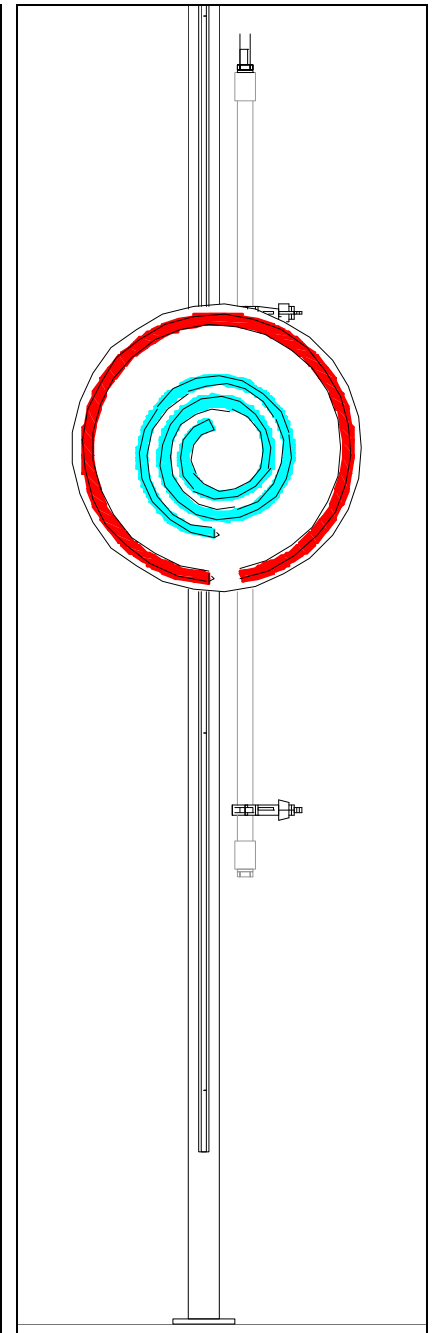
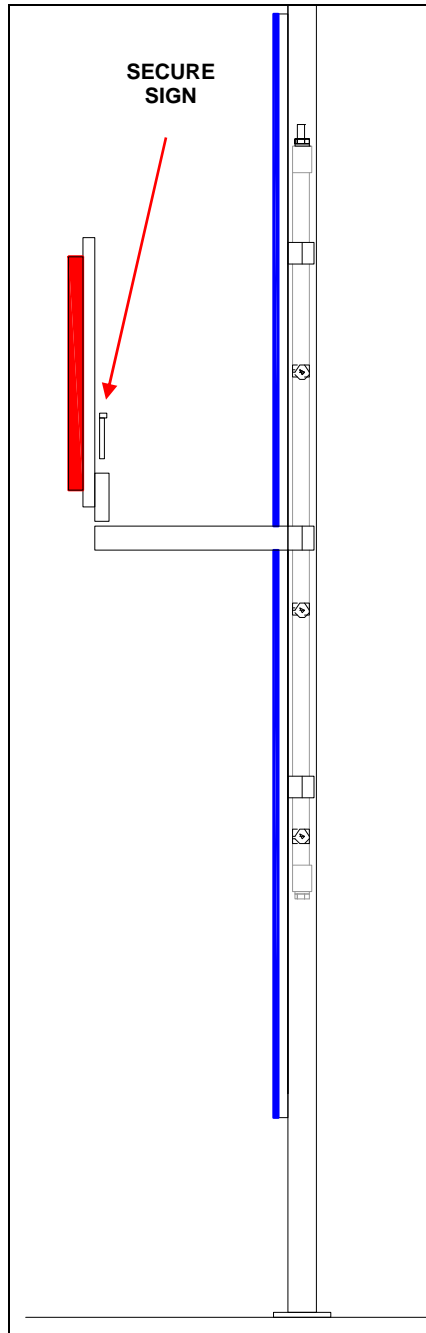
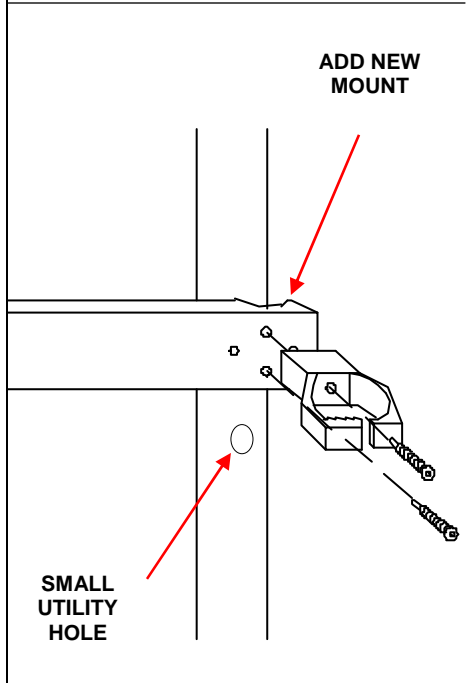
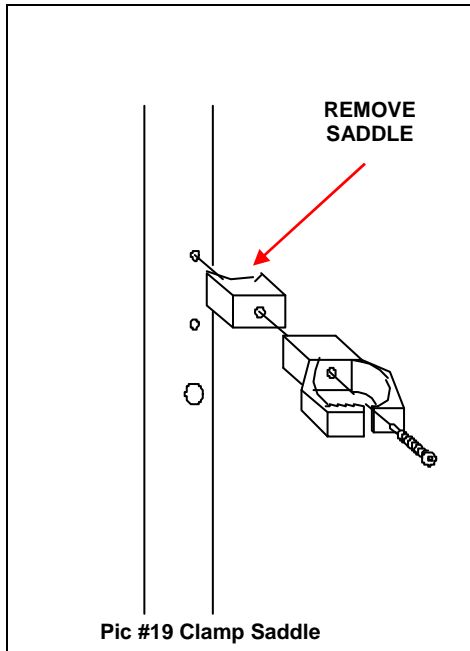

- Secure** the sign at the end of the mount using the supplied fasteners like shown on picture # 27. Position the sign to be visible from the vehicle in the wash bay (see Picture #21).
- Pull** the two cables coming from the sign through the leg using the small utility hole located below the manifold clamp (see Picture #20) an out with the existing LED String cable through the large utility opening located on the side of the leg (see Picture #23).

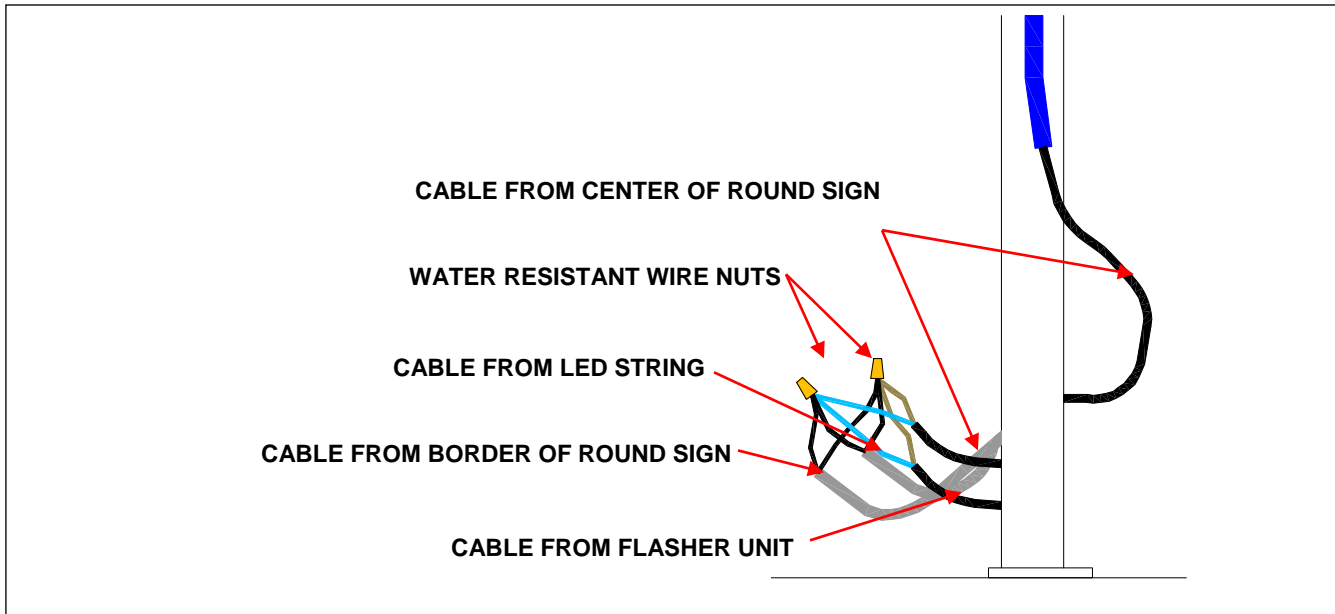

Pic #23: LED Cable Through Utility Holes

- Install** the power supply in the Mechanical Room or in a dry area of the wash, close to a 120 VAC power outlet. Install the flasher assembly close to the power supply.
- Pull** a 2 or 3 conductors cable at least #16 AWG size from the arch to the flasher unit.
- Connect** the corded end of the power supply to the flasher unit (see Picture #24) and from the flasher unit to the arch LED lights following one of the two **ELECTRICAL DIAGRAMS** shown in the next section.

STOP!

DO NOT OVERLOAD THE FLASHER UNIT POWER SUPPLY!

4.2 MAX AMPS ALLOWED PER POWER SUPPLY

ROUND SIGN = 1 AMP EACH
CORNER SIGN = 1.2 AMPS EACH
BORDER LIGHT (26 FT) = 2.6 AMPS EACH



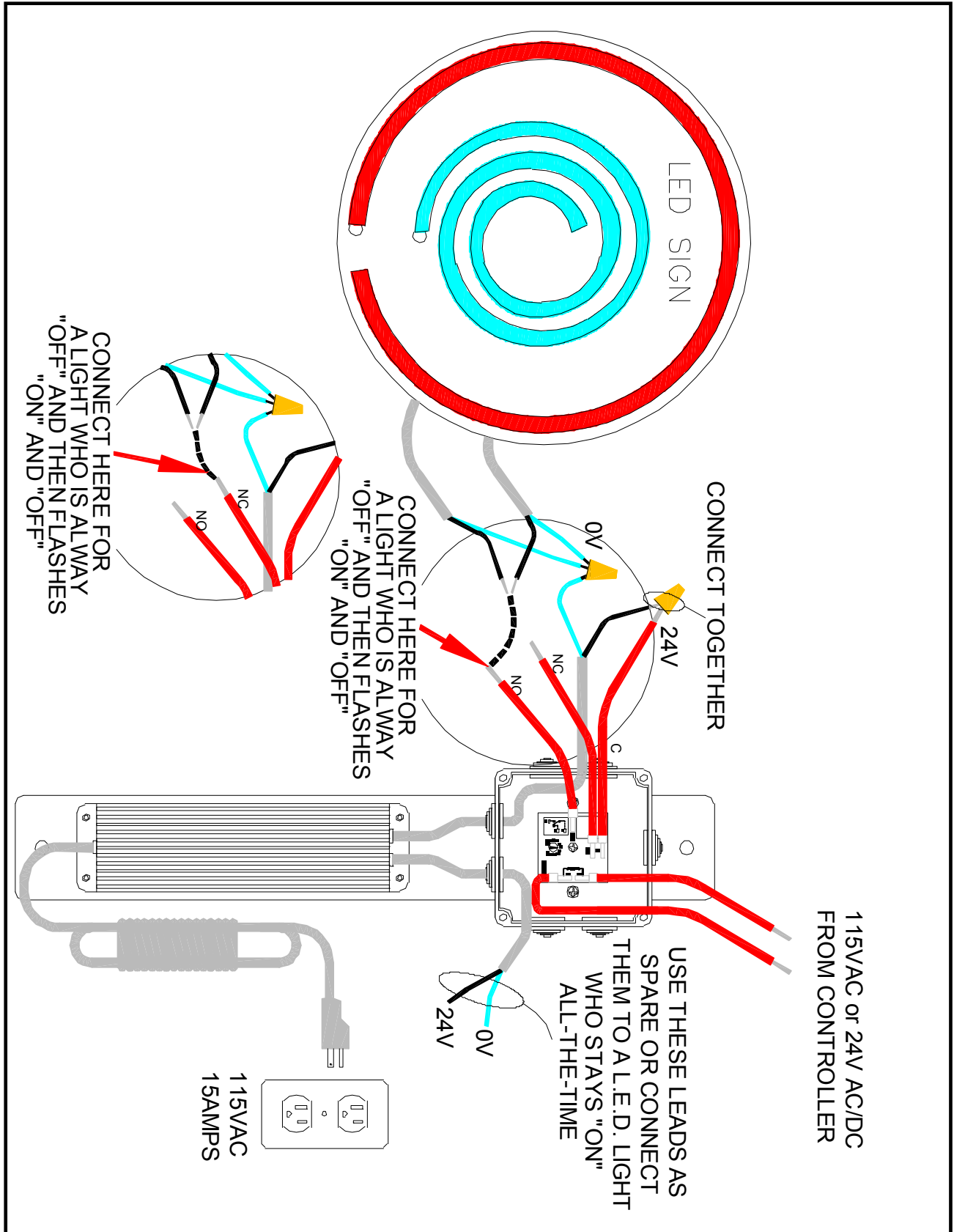

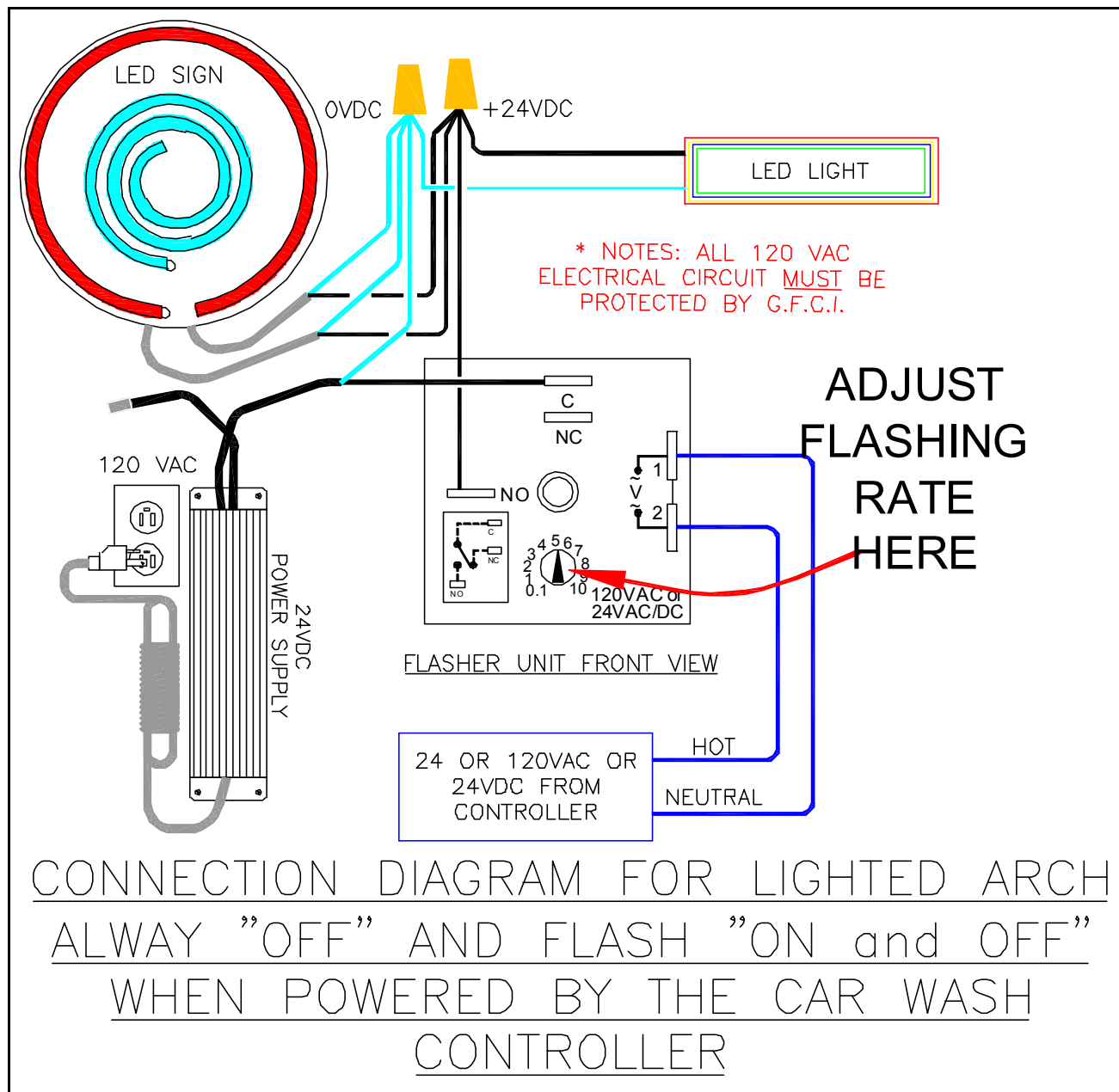

Pic #11: Connection Diagram of Flasher Unit with Light Always OFF

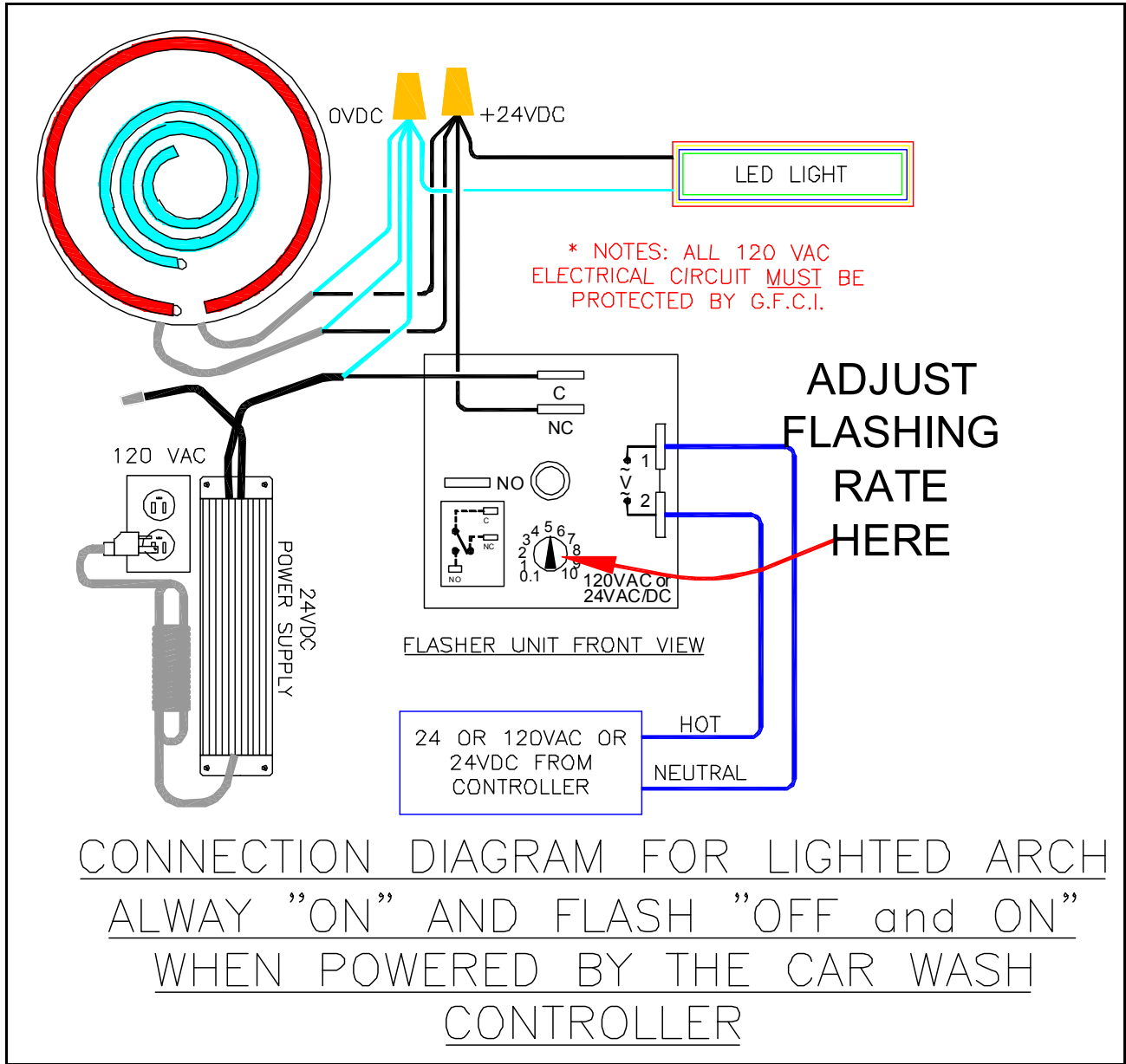

Pic #12: Connection Diagram of Flasher Unit with Light Always ON

Start Up and Operation

-  Plug the power supply into the power outlet and turn ON manually the car wash controller output. Your lighted arch is now flashing!



NOTE: IF THE LIGHTS DON'T WORK, IT MAY BE CONNECTED BACKWARDS. REVERSE THE WIRE POLARITY IN THE FLASHER BOX

- Open the cover of the flasher enclosure. By turning the flasher knob, adjust the flashing rate to your desire.

Warranty and Return Procedure:

Motor City Wash Works warrant this product to be free of defects in material and/or workmanship for a period of **one year** from the date of purchase. During the warranty period MCWW will at its discretion, at no charge to the customer, repair or replace this product if found defective, with a new or refurbished unit, but not to include costs of removal or installation. Any product returned to MCWW for warranty has to have a **Return Material Authorization Number**. All shipping costs to MCWW are assumed by the customer. This is only a summary of **MCWW's Limited Warranty**. Please, communicate with MCWW for our complete warranty.

Prior to returning any product to MCWW, the customer must call in for a **Return Material Authorization Number** and a copy of our **Return Material Authorization** Form must be completed. The **RMA** number must be written clearly on the outside of the shipping package and a copy of the form must be included in the package.