

- Pull** and install all the tubing between the dilution station and your applicators according to the applicators installation requirements.

Start-Up and Operation

-  **Using** table #1, select the proper Hydrominder® “TIP” for the dilution ratio. Drop the suction line into each chemical drum and open the Hydrominders® water shut off valve, let the tanks fill and adjust the position of the float to avoid any overspill when the Hydrominder® valve is shut off.

TIP COLOR	DILUTION RATIO	TIP COLOR	DILUTION RATIO
NO TIP	4:1	TAN	36:1
GRAY	5:1	GREEN	48:1
BLACK	6:1	ORANGE	64:1
BEIGE	8:1	BROWN	75:1
RED	17:1	YELLOW	90:1
WHITE	23:1	PURPLE	120:1
BLUE	25:1	PINK	240:1

Table #1: Dilution Ratio @ 40 PSI

- Collect** a sample of the diluted solution and titrate if required. Change the colored Hydrominder® “TIP” for a different concentration if needed and repeat the same process.
- Push** and rotate 1/4 turn and lock the air solenoid manual override button.
- Adjust** the pump air regulator to about **30 PSI** and let it pump the solution to the applicators until the proportioner’s float valve opens to refill the tank. Ensure that the level of diluted solution never drops below the pump suction line strainer. Readjust the float level as needed.
- While** the pump is still running, set each foam air regulator to about **20 PSI** and visually confirm that foam is produced at the applicators. **Note: increasing the pump air pressure will increase the amount of solution delivered to the applicators, therefore making the foam “wetter”. Increasing the foam air pressure may increase the foaming effect of the solution and also spray the foam further from the applicator.** Adjust foam to desired consistency.
- While** the unit is running, go to the applicators and “balance” the flow of solution and air from the driver’s side applicator to the passenger’s side by closing or opening slightly the air and/or the solution ball valves on each applicator. **Adjust** the direction of each applicator in order to optimize the coverage on the vehicles.
- When** proper adjustments are reached, release the air solenoid manual override button by turning another 1/4 of a turn. The valve should now be shut off.
- Test** the system by overriding **ON** the function switch at the car wash controller output unit.
- Finally** test the system with a car being washed through the tunnel and fine tune the position and the coverage on the car of each applicator.

Preventive Maintenance Tips

-  **Inspect** each applicator for wear and/or visible damages. Replace any damaged applicators.
- Remove** the foam generator assembly from the applicator base, remove the plastic mesh and clean it periodically with warm soapy water. Keeping the foamer generator cleaned of deposits will guarantee the applicators are at maximum efficiency... for years to come!!!

Warranty and Return Procedure

Motor City Wash Works warrants this product to be free of defects in material and/or workmanship for a period of **one year** from the date of purchase. During the warranty period MCWW will at its discretion, at no charge to the customer, repair or replace this product if found defective, with a new or refurbished unit, but not to include costs of removal or installation. Any product returned to MCWW for warranty has to have a **Return Material Authorization Number**. All shipping costs to MCWW are assumed by the customer. This is only a summary of **MCWW’s Limited Warranty**. Please, communicate with MCWW for our complete warranty.

Prior to returning any product to MCWW, the customer must call in for a **Return Material Authorization Number** and a copy of our **Return Material Authorization** Form must be completed. The **RMA** number must be written clearly on the outside of the shipping package and a copy of the form must be included in the package.

Drawings

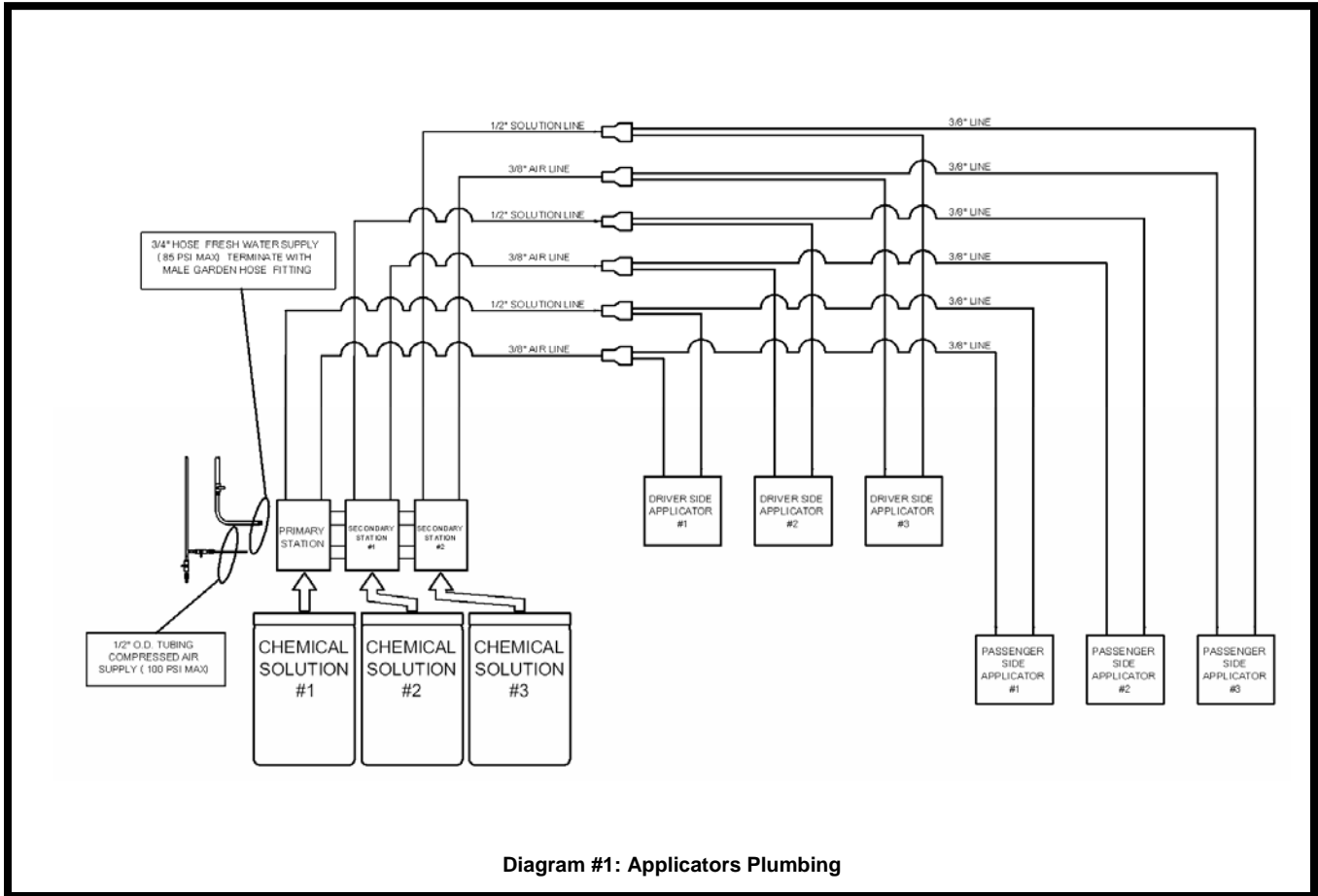

Replacement Parts

8FTNGAIRSRT001
Straight Fitting 1/8" FPT X 1/4" Tube

8VALVAIRSOL0001
3 Way Solenoid Air Valve

8FTNGAIRELB0001
Elbow Fitting 1/4" MPT X 3/8" Tube

8FTNGAIRELB0002
Elbow Fitting 1/8" MPT X 1/4" Tube

8FTNGAIRTEE0002
Tee Fitting 1/4" MPT X 3/8" Tube

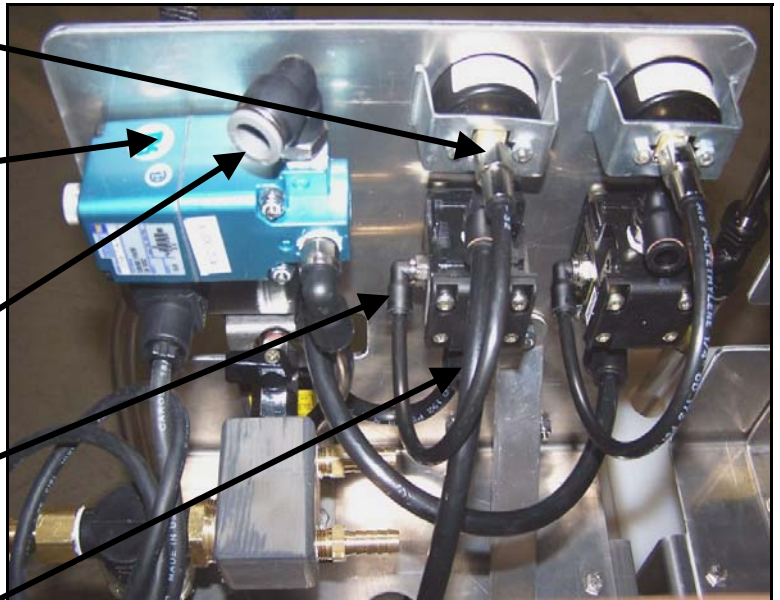



8VALVHYMFOT0001
Gray Push-on EPDM Foot Valve

8VALVHYMFOT0002
Blue Push-on VITON® Foot Valve

8VALVHYMTIP0001
Hydrominder® Metering Tips Kit

8VALVHYMWGT0001
Ceramic Weight

8TUBECHMCLR0004
100' Roll 3/4" Vinyl Clear Tube



8VALVHYMFLT0001
Hydrominder® 511 Float Valve Assembly

8VALVHYMEDU0001
Hydrominder® 511 Eductor Assembly

8PUMPCHMAIR0001
Santoprene® Flojet® Air Pump

8PUMPCHMAIR0002
Viton® Flojet® Air Pump

8APPLTNKHYM0001
Dilution Station Tank Assembly